

University of Mumbai

Program: _First Year (All Branches) Engineering - SEM-II

Curriculum Scheme: Rev 2019

Engineering Graphics

Question Bank

Projections of Line	
1.	A line AB 65 mm long, has its end A 20 mm above the H.P. and 25 mm in front of V.P. The end B is 40 mm above the H.P. and 65 mm in front of the V.P. Draw the projections of AB and show its inclinations with the H.P. and V.P.
2.	Draw the projections of a line AB when its end A is 20 mm above H.P. and 10 mm in front of the V.P., its end B is 55 mm above the H.P. and 60 mm in front of the V.P. and distance between end projectors of line AB is 45 mm. Determine its true length, and inclination of line with the H.P. and V.P.
3.	The top view and the front view of a line AB measures 70 mm and 58 mm respectively. The line AB is inclined at an angle of 35° to the HP. The end A is 15 mm above the HP and 12 mm in front of the VP. The other end B is also in the first quadrant. Draw the projections of line AB and find its true length and true inclination with the VP.
4.	A line AB is inclined at 30° to VP while its front view is inclined at 50° to xy. Draw projections of the line and find its true length and true inclination with HP if the FV measures 60mm. One end of the line is 20mm below HP and 35 mm in front of VP while another end is in the first quadrant.
5.	A straight-line AB has its top and front views inclined at 30° and 45° to xy line respectively and front view length measures 50 mm. The end A is 10 mm above the HP and 20 mm in front of the VP. The other end B is also in the first quadrant. Draw the projections of line AB and find its true length and true inclination with H.P. and VP
Engineering Curves	
6.	An in-elastic string, of 100 mm length, is wound round a cylinder of 40 mm diameter, keeping the string always tight. Draw the curve generated by end point of string. Name the curve.

7.	Draw the curve traced by a point on the circumference of a disc of 50 mm diameter, which rolls along the ground for one complete revolution. Take initial position of generating point as a contact point of disc with ground. Also draw normal and tangent to the curve at any suitable point on the curve.
8.	Trace the paths of the ends of the straight-line AP, 100 mm long, when it rolls, without slipping, on a semicircle having its diameter AB, 75 mm long (Assume the line AP to be tangent to the semicircle in the starting position).
9.	Draw a single start helix for one revolution having pitch of 40 mm and diameter of the cylinder is 60 mm
10.	Draw a hexagon ABCDEF of 25 mm sides with two of its sides AB & DE being vertical. An inelastic string is attached at corner C of the hexagon and wound around its perimeter completely. Holding the free end of the string such that the string is always tightly stretched the string is unwound completely. Trace the path of the free end. Name the curve.
Projection of solids	
11.	A pentagonal pyramid, base edges 40 mm and axis length 75 mm rests on its slant edge on H.P., which is inclined at 45° to V.P. Draw its projections with apex nearer to the observer.
12.	A square prism, side of base 30 mm and axis length 60 mm is kept on the H.P. on a corner of its base such that its axis makes an angle of 30° to both H.P. and V.P. Draw the projections of the prism.
13.	A right circular cone of diameter 50 mm and axis 60 mm is lying on HP on one of its end generator with the top view of the axis makes an angle of 45 degrees to VP. Draw projections of the Cone.
14.	A cylinder of diameter 45 and axis 60 mm long is resting on a point of its base on H.P. with axis inclined at 35° to H.P. Draw the projections of cylinder if its axis appears perpendicular to V.P.
15.	A pentagonal pyramid, base edges 25 mm and axis length 50 mm long has one of its triangular faces in the V.P. and edge of the base contained by that face makes an angle of 30° with H.P. Draw its projections.
16.	A regular pentagonal pyramid with the sides of its base 30 mm and height 80 mm rests on an edge of base. The base is tilted until its apex is 50 mm above the level of the edge of the base on which it rests. Draw the projection of the pyramid when the edge, on which it rests, is parallel to the V.P. and the apex of the pyramid points towards V.P.

17.	A pentagonal pyramid, side of base 30 mm and axis 65mm long is resting on one of its corners on HP such that one of the triangular surfaces is parallel to HP and perpendicular to VP. The base edge containing that triangular surface is parallel to both HP and VP. Draw the projections of solid when the apex of the pyramid is nearer to observer.
18.	A regular pentagonal pyramid with the sides of its base 35 mm and height of axis 70 mm rests on one of its base edge in H.P. The solid is tilted such that the triangular face contained by the base edge in H.P. is parallel to V.P. and perpendicular to H.P. Draw the projections of the pyramid when the base of the pyramid is completely visible to the observer.
19.	A cone diameter of base 70 mm and height of axis 80 mm is resting on a point of its base circle on H.P. with the axis making 50° with the H.P. The axis of the solid is parallel to V.P. It is cut by a section plane which is parallel to H.P. and perpendicular to V.P. and bisects the axis. Draw sectional top view.
	Orthographic Projection.
<u>20.</u>	For the object shown in figure draw the following views – Refer Figure No. 2 (i) Sectional front view along section A-A. (ii) Top view (iii) Left hand Side View (iv) Insert the major dimensions

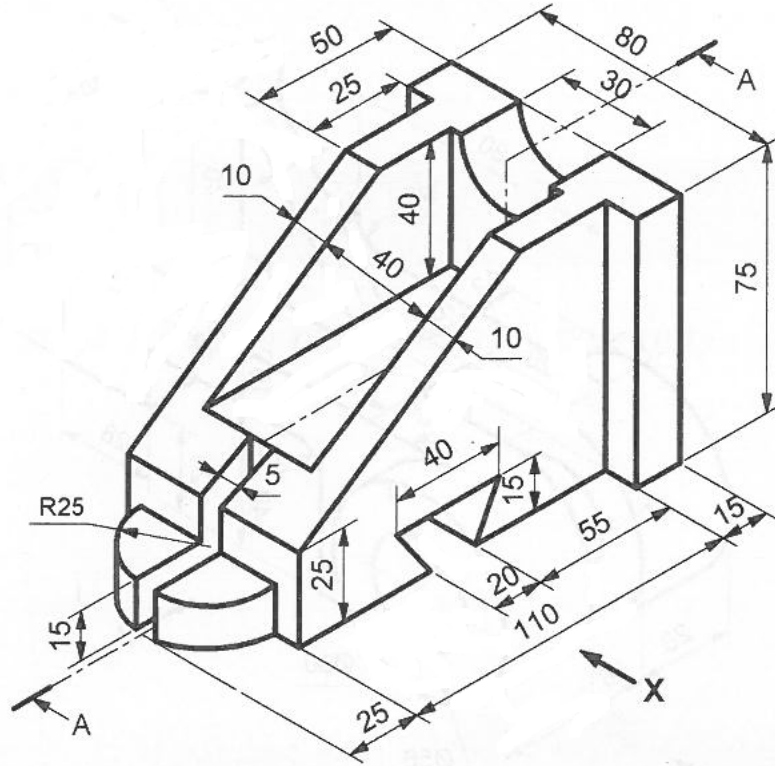

21.

Draw the following views.

- (i) Sectional front view along section A-A.
- (ii) Top View
- (iii) LHS View
- (iv) Insert Major dimensions

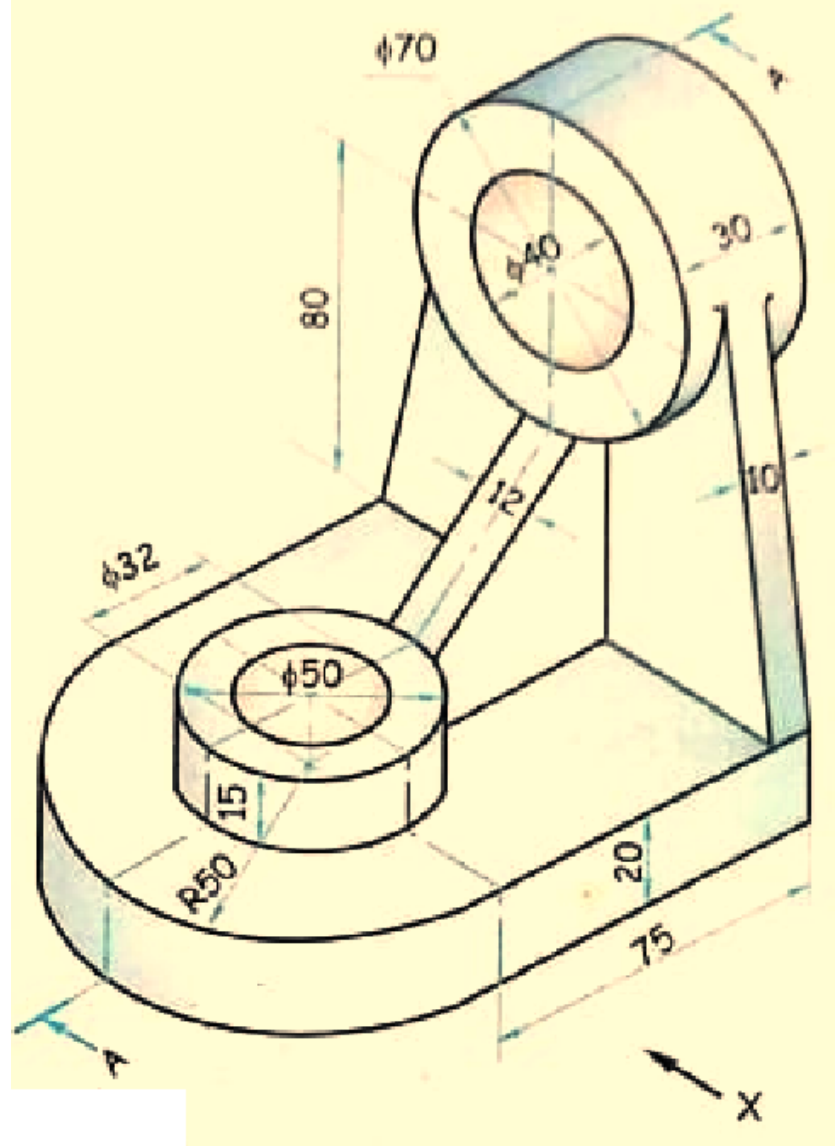

22. Figure shows pictorial view of machine part. Draw the following views.
- (a) Sectional FV along A-A,
 - (b) LHSV
 - (c) TV.
 - (d) Show major dimensions

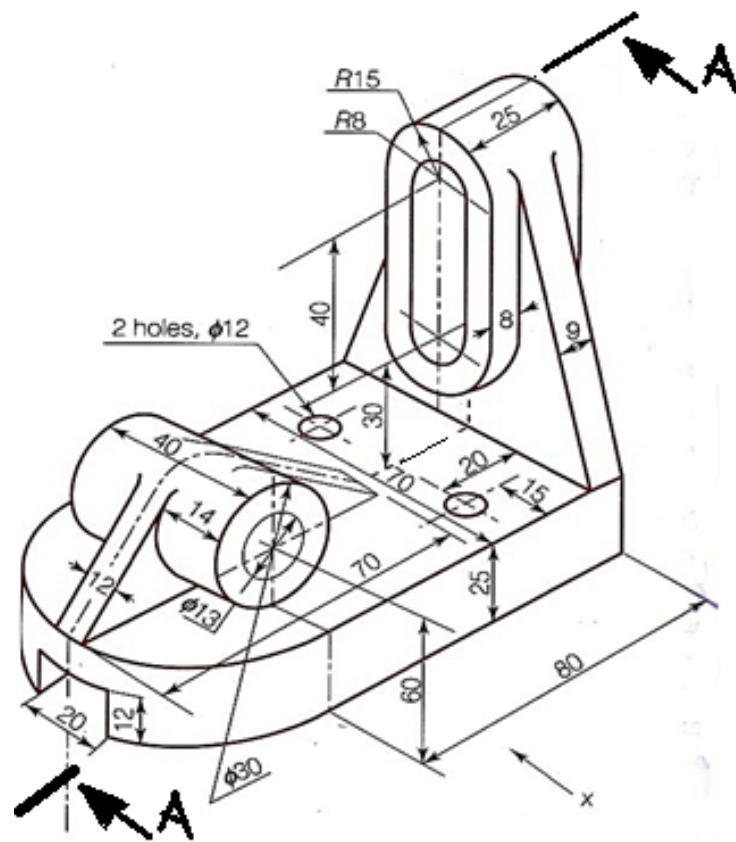

23.

Figure shows pictorial view of a machine part. Draw the following views.

(a) Sectional FV along section plane B-B,

(b) LHSV

(c) TV.

(d) Show Major dimensions.

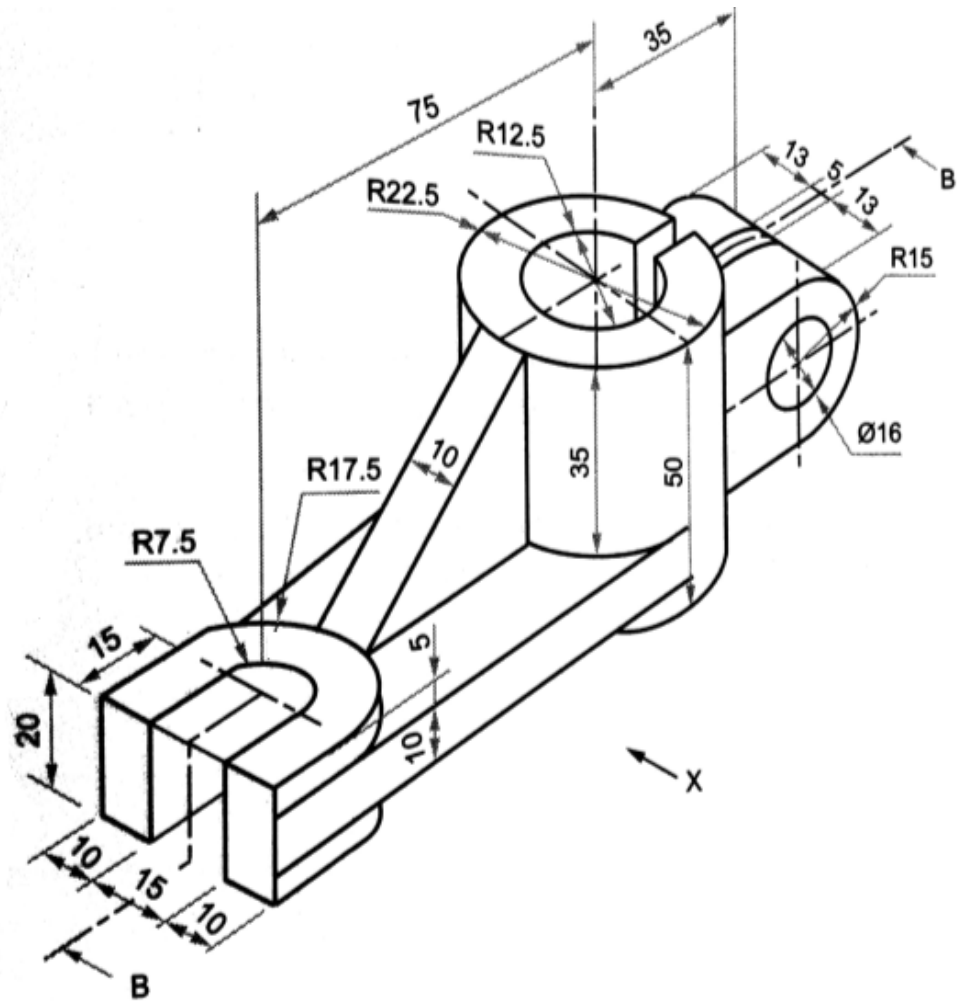

24. Figure shows pictorial view of a machine part. Draw the following views.
- Sectional FV along section plane A-A,
 - LHSV
 - TV.
 - Show all dimensions

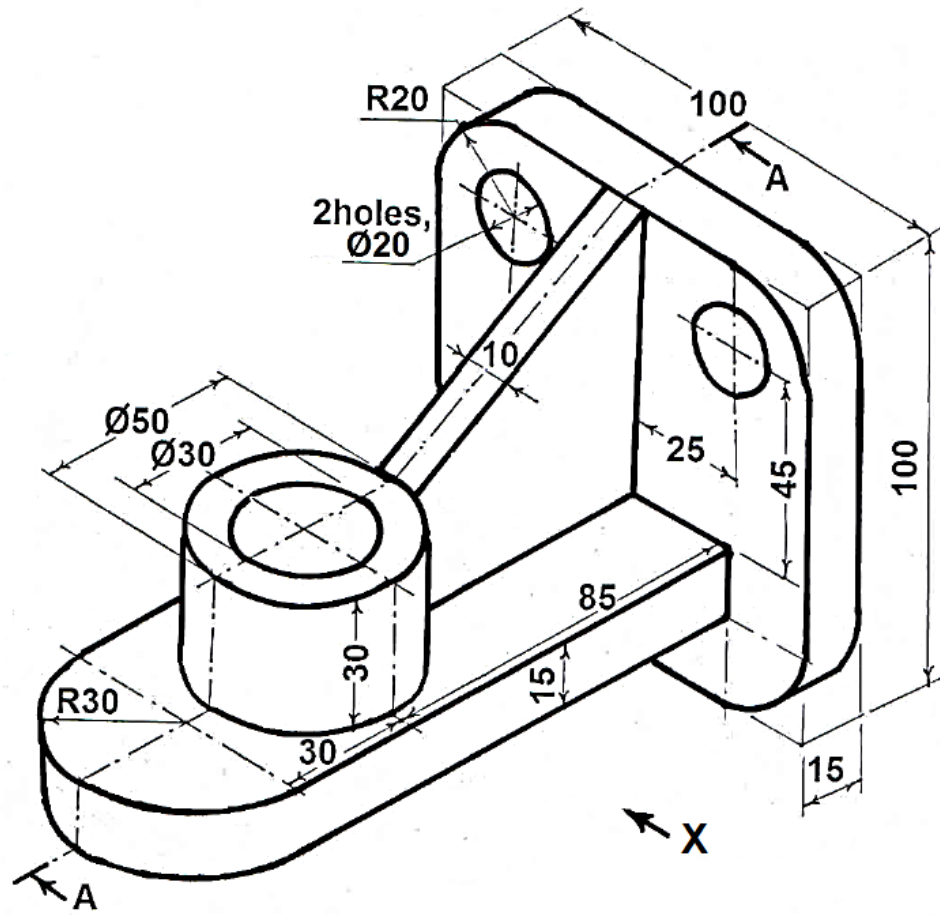

Isometric Projection

25. Figure shows two views of an object. Draw isometric view of the object.

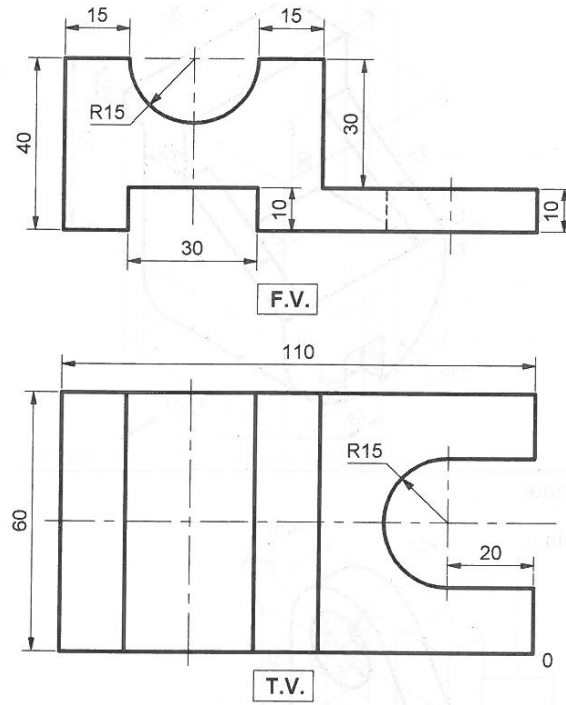

26. Figure shows two views of a casting. Draw an isometric view with suitable origin.

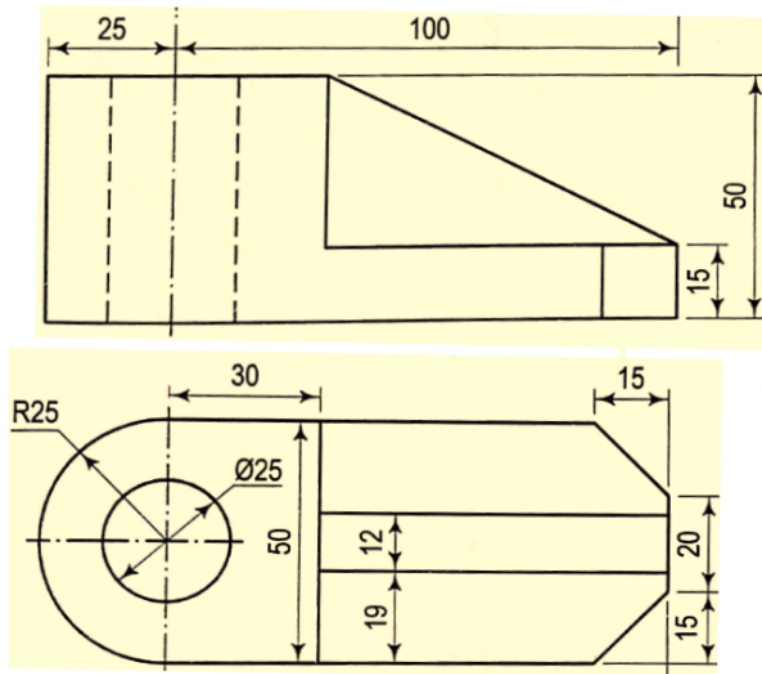

27. Draw isometric view of an object whose views are shown in Figure.

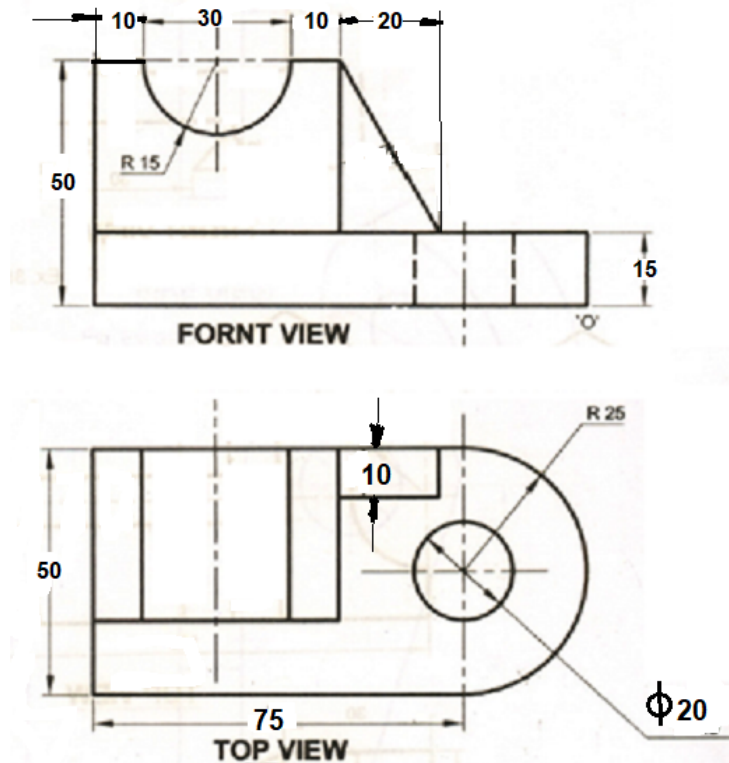

28. Draw isometric view of an object whose views are shown in Figure.

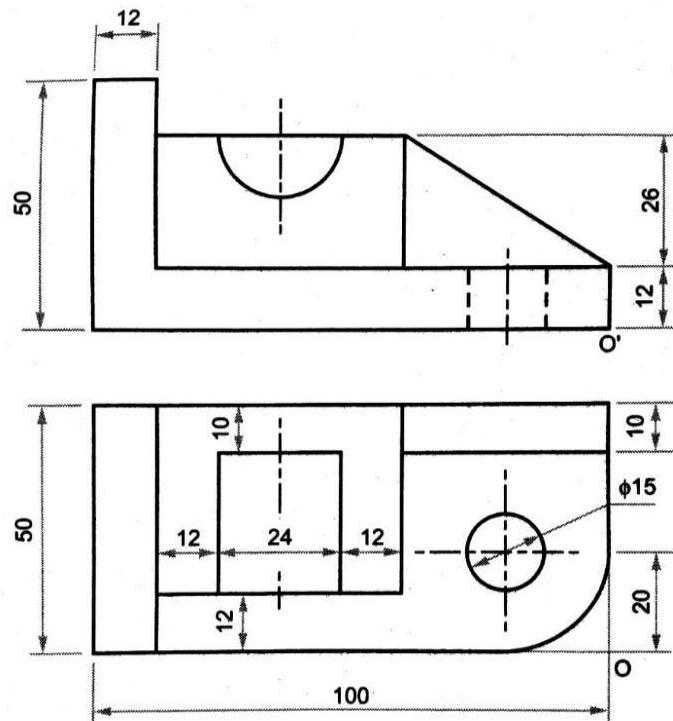

29. Draw isometric view of an object whose views are shown in Figure.

