

# Engineering Drawing (Rev-2012 and Rev-2016) Backlog Examination

## SET B

Total marks: 30

Time: 1hr 30 minutes.

### Q. 1. Attempt any one

5

- A Steel ring of radius 25 mm rolls without slipping on a Horizontal surface for complete revolution in counter-clockwise sense. Draw the path traced by a Point P which was the topmost point on the ring, initially. Name the curve.
- A line MN has its Elevation Length equal to 50 mm and Plan Length equal to 60 mm. If the distance between end projections is 40 mm, draw the line's Projections and find its inclination with the HP. Also find its True Length. Point M is at 20 mm equidistant from both the principal planes.

### Q. 2. Attempt any one

15

- Draw following Orthographic Views for the object shown in **Figure a.**:
  - Sectional Elevation View along Section X-X (05)
  - Left Hand Side View (04)
  - Plan View (04)
  - Insert the Major Dimensions (02)

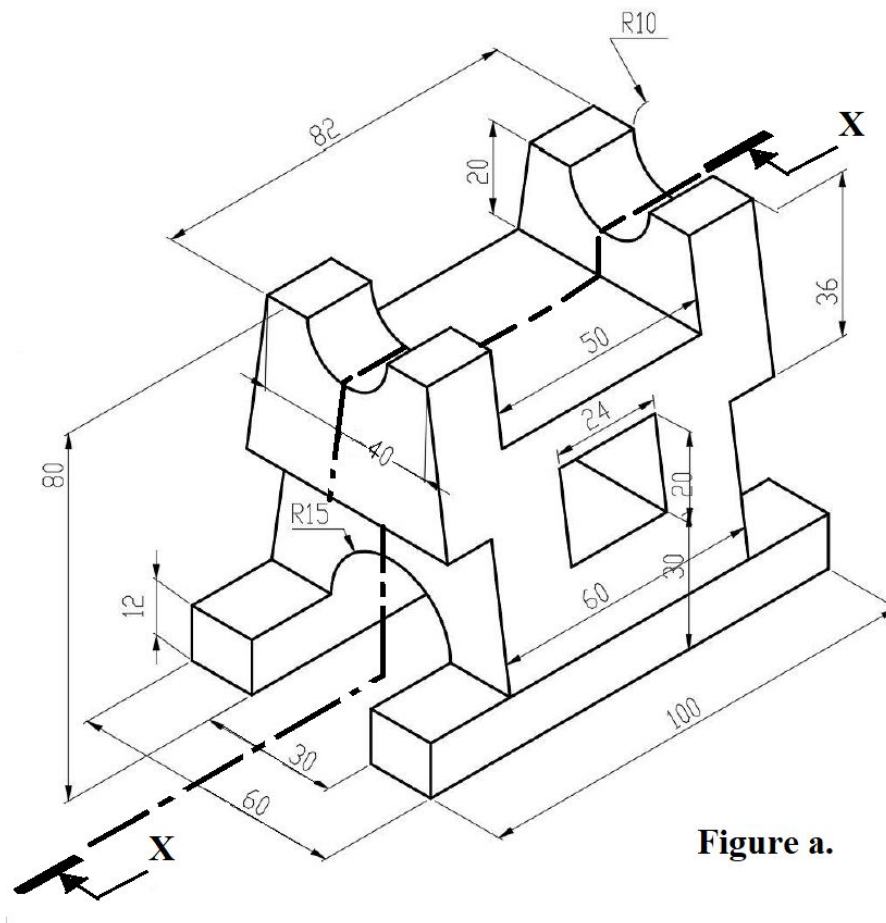

Figure a.

- b. A Regular Cone of base diameter 50 mm is lying on one of its circumferential points on the VP such that the base makes an angle of  $45^\circ$  with the VP. The tip of the axis touches the HP. The FV of the axis makes  $65^\circ$  with the XY line and the TV measures 55 mm. Draw the projections of the Solid.

**Q. 3. Attempt any one**

**10**

- a. Draw the Projections of a Hexagonal Prism of base edge of 60 mm and 70 mm long axis. The solid is resting on one of its base corners on the HP such that its two rectangular surfaces are parallel with each other and with the VP. The edge containing this corner makes  $25^\circ$  with the HP.
- b. For the given Orthographic Views, draw Isometric view.

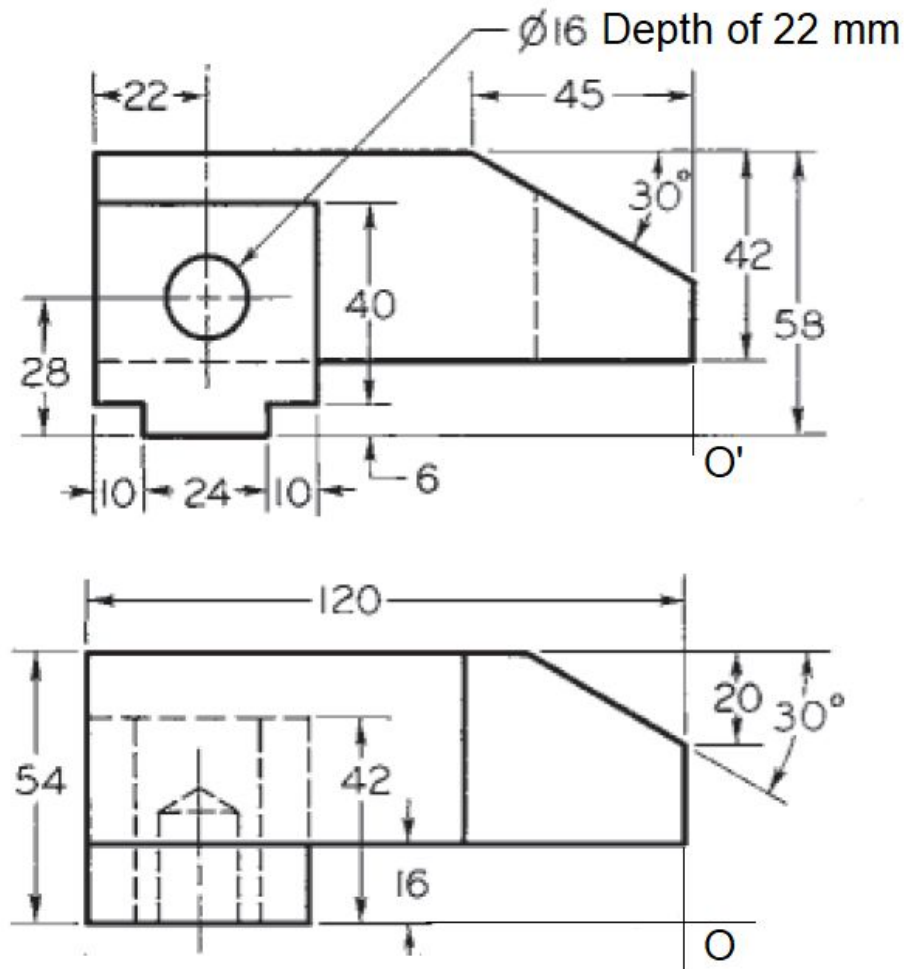

\*\*\*\*\*